

THIS DRAWING IS UNPUBLISHED. RELEASED FOR PUBLICATION -,- .
 © COPYRIGHT - BY TYCO ELECTRONICS CORPORATION. ALL RIGHTS RESERVED.

LOC	DIST	REVISIONS					
AF	50	P	LTR	DESCRIPTION	DATE	DWN	APVD
			D1	REV PER ECR-06-005312	10APR06	HMR	GP

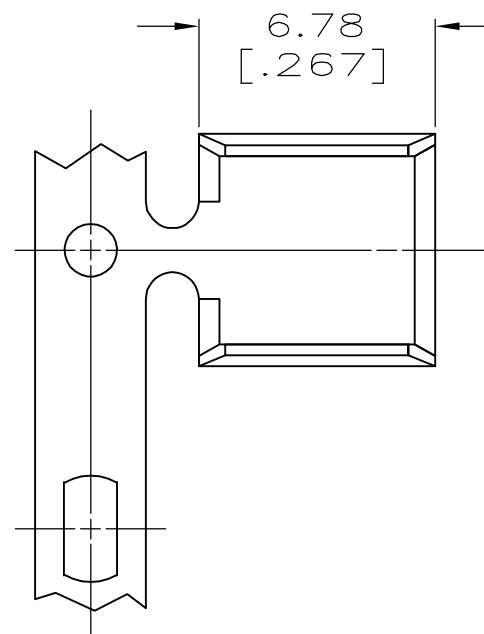

- 1 STRIP PRODUCT PROVIDED ON REEL.
- 2 REF CRIMPING INFO:
 4.57 [.180] CRIMP WIDTH AT CRIMP HEIGHT = (CMA+23,100) /285,700
 5.58 [.220] CRIMP WIDTH AT CRIMP HEIGHT = (CMA+24,500) /330,000
- 3 REF SIMILAR SLICE P/N 1217967-X WITH SERRATIONS
- △ 4 0.002032 [.000080] MIN TIN PLATE.

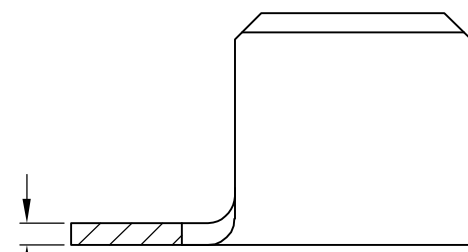

0.635±0.025
 [.025±.001]

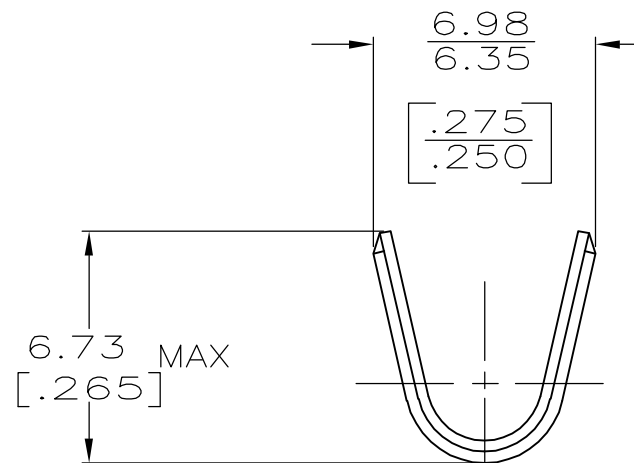

△ 4	2.5-8.1mm ²	63625-2
	5,000-16,000 CMA	63625-1
FINISH	WIRE RANGE	PART NO

THIS DRAWING IS A CONTROLLED DOCUMENT.		DWN P FORTNEY 10/3/91	Tyco Electronics Corporation Harrisburg, PA 17105-3608			
DIMENSIONS: mm [INCHES]		CHK MS FEHER 10/4/91				
TOLERANCES UNLESS OTHERWISE SPECIFIED:		APVD R WEAVILL 10/4/91	NAME			
0 PLC ± - 1 PLC ± - 2 PLC ± 0.25 [.010] 3 PLC ± - 4 PLC ± - ANGLES ± -		PRODUCT SPEC	SPLICE			
MATERIAL H04 BRASS	FINISH SEE TABLE	APPLICATION SPEC	SIZE	CAGE CODE	DRAWING NO	RESTRICTED TO
		WEIGHT	A3	00779	C-63625	-
CUSTOMER DRAWING			SCALE	SHEET	REV	
			5:1	1 OF 1	D1	